

For high current signal sampling, tolerance down to $\pm 0.5\%$

AEC-Q200 qualified, high stability, ultra-low thermal EMF and TCR

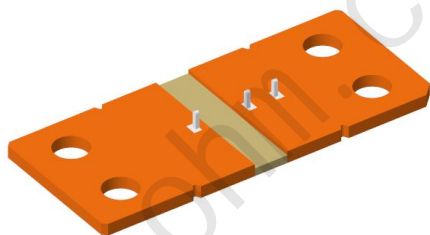

Features:

- determining the sampling location of Pin-type shunt resistors can be used for temperature drift compensation, suitable for accurate sampling in PCB boards that are welded
- Vacuum electron-beam welding
- Rated current: 1000A
- maximum tightening torque is 10N
- high reliability and stability ,superb pulse load capability
- The shunt's copper terminals plates with nickel and tin, which prevents oxidation and ensures better electrical connections.
- RoHS compliant

parameter:	
Rated power	1000A
resistance value	50 $\mu\Omega$
tolerance	$\pm 1\%$, $\pm 5\%$
TCR	$\pm 150\text{ppm}$
temperature range	-55°C至+170°C
thermal EMF	<1 $\mu\text{V}/^\circ\text{C}$
inductance	<5nH

Dimensions(mm):

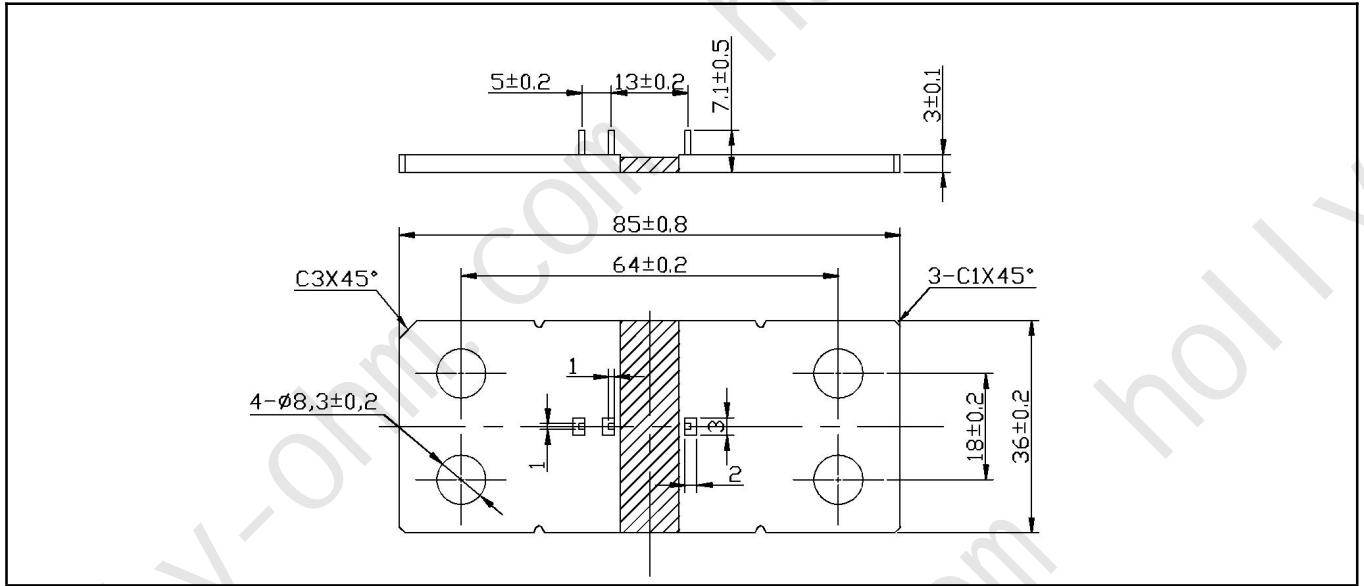

Type Designation(example): HYCS8536L050J3P											HYCS8536 0.05mΩ 5% standard			
H	Y	C	S	8	5	3	6	L	0	5	0	J	3	P
HYCS Flat shunt				Size 8536			Resistance value L050 = 0.05mΩ			Tolerance F=±1% J=±5%		Code 3P: 3Pins		

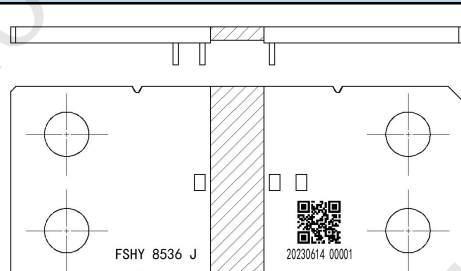
QR code rules:					
					
QR code content	example: FSHY20230613-0001R50945n				
	FSHY	20230613-0001		R24945n	
	supplier	batch no.		Resistance value(unit: nΩ)	
plaintext content	FSHY	8536	J	20230614	00001
	supplier	Model size	tolerance	Production date	Serial number

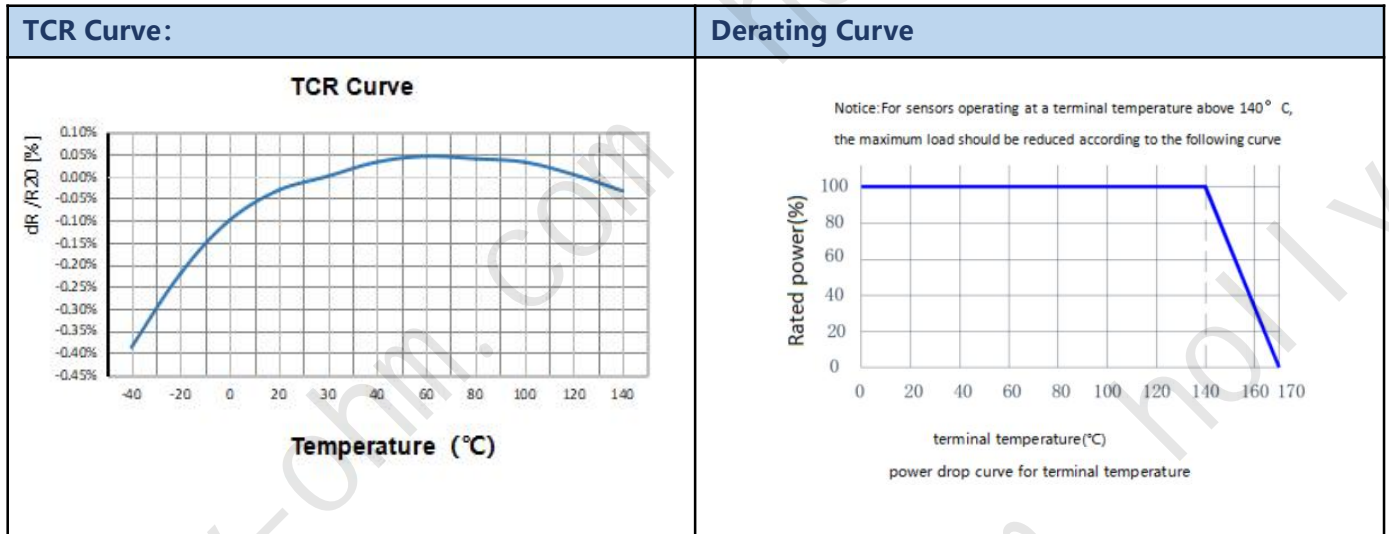

Performance:		
Test Item	standard	Test method
TCR	Within specified TCR	IEC60115-1 4.8, measured point -40°C ~ +140°C, reference point +20°C
Resistance to soldering heat	No visible damage ΔR±0.5% Maximum	IEC60115-1 4.18, 260°C tin bath, 10s
load life	No visible damage ΔR±1.0% Maximum	IEC 60115-1 4.25.1, 1000hrs., 70°C±2°C, rated current, or the maximum current rating of the component (whichever is lower) is applied for 1.5 hours/0.5 hour interruption
High temp. & high humidity	No visible damage ΔR±1% Maximum	Applying 10% of the rated power (current) or the maximum current of the component (whichever is lower) for a duration of 1000 hours in a temperature of 85°C and a humidity of 85% according to MIL-STD-202 method 103
temperature cycle	No visible damage ΔR±1% Maximum	IEC60115-1 4.19, -55°C@30mins ~ +155°C@30mins, 1000 cycles
High temperature storage	No visible damage ΔR±1% Maximum	IEC60115-1 4.25.3, 1000hours@170°C, without loading current and voltage
Low temperature load	No visible damage ΔR±0.5%Maximum	IEC60115-1 4.36, cooled from room temperature to -55°C, no load for 1.5 hours, applying rated power, continuously flowing for 45 minutes, cool for 15 minutes, then recover to room temperature for testing again.
vibration	No visible damage ΔR±0.5% Maximum	MIL-STD-202 Method 204 peak acceleration: 5g (gravity acceleration) frequency varied: (10~2000Hz) test direction: X, Y, Z direction, 12 cycles in each direction, each cycle 20min, total about 12h
Impact test	No visible damage ΔR±0.5% Maximum	MIL-STD-202 Method 213 Impact acceleration: 100g (gravity acceleration) Impact pulse width: 6ms

		Impact waveform: half sine wave Impact direction: $\pm X$, $\pm Y$, and $\pm Z$ directions each 3 times
--	--	--------------------------------------------------------------------------------------------------------------

包装规格及尺寸(单位mm)

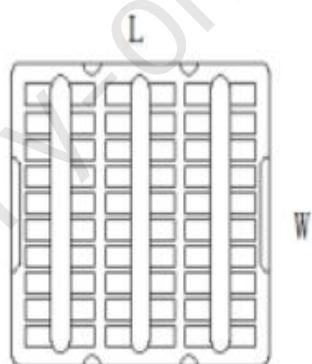

tray

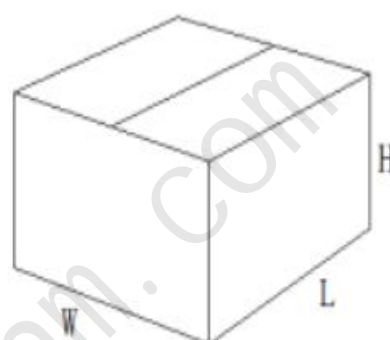

carton

specification	pieces/layers	L (mm)	W (mm)	H (mm)
tray	18pcs	350	350	15
carton	9layers	360	360	150

Disclaimer:

All product, product specifications and data are subject to change without further notice. Product specifications are not enlarged or modified in any other way, FSHY makes no statement or guarantee except for the specifications in the sales terms and conditions. The information provided in data sheets or specifications may vary from actual results in different applications. Any statement made by FSHY regarding the suitability of its products for certain types of applications is based on its knowledge of the typical requirements placed on its products.

version update record

Version NO.	update record	person in charge	发布日期
A0	updated version release	Fameng Hong	14Oct2023

